

# GS/P 25S4 1185X555

## THE HOMOLOGATED SCALE PALLET TRUCK



### SCALE TRUCK GS/P

The GS/P pallet truck is an intelligent and robust tool to be used for weighing and transporting your loads at the same time, making stock and dispatch processes faster, simpler and more efficient. The machine can be equipped with supplements such as printer or SD memory card and thanks to the 4 load cells it is able to be very precise and functional; ideal for checking incoming goods, avoiding overloads and determining shipping weights.



### DISPLAY

Its large-sized 6 digits LCD display provides accurate and precise weighing in kg and lb. Its software allows not only net/gross/tare weighing but also unit counting, adding and totalling of multiple loads. Weights are shown in 1 kg/lb steps with 0,05% precision.



### FRAME STRUCTURE

The structure is designed with a double frame consisting of a lower fork on which stands a counter fork. Both forks house two load cells allowing a uniform load distribution, and keeping high weighing accuracy even in case of collision and unbalanced load.



## BATTERY and BATTERY CHARGER

The GS/P is supplied complete with rechargeable battery and charger. The battery module provides 50 hours autonomy.



## CONFIGURATION

### STANDARD:

Nylon polyurethane steering wheels and polyurethane rollers



### OPTIONAL:

Rubber steering wheels



## PRINTER / USB (Supplement, only available at time of order)

As supplement, the machine can be equipped with a built-in printer, able to print gross, tare and net weights (kg or lb), date, quantity of pieces on the scale.

It may also be enriched with another supplement, the USB, allowing you to store weighing data in a text file, for archiving and processing via PC.



## Descriere

1.1 Producător			LIFTER
1.3 Comandă			Manual
1.4 Poziție operare			Pedestru
1.5 Capacitate maximă	Q	Kg	2500
1.6 Distanța la centrul de aplicare al sarcinii	c	mm	600
1.8 Sarcina de la osie la capătul furcilor	x	mm	975
1.9 Ampatament	y	mm	1250

## Greutăți

2.1 Greutate de operare (acumulator inclus)		Kg	117
2.2 Sarcină osie, încărcare pe spate		Kg	1836
2.2 Sarcină osie, încărcare pe față		Kg	781
2.3 Sarcină osie, liber față		Kg	71
2.3 Sarcină osie, liber spate		Kg	46

## Cauciucuri/Șasiuri

3.1 Cauciucuri: roți direcție			POLY.I./ NYLON
3.1 Cauciucuri: transportoare cu role			POLY.I.
3.2 Mărime cauciuc: roți direcție - Lățime		mm	55
3.2 Mărime cauciuc: roți direcție - Diametru		mm	200
3.3 Mărime cauciuc: transportoare cu role - Diametru		mm	82
3.3 Mărime cauciuc: transportoare cu role - Lățime		mm	60
3.5 Dimensiune cauciuc: roți spate		nr	4
3.5 Dimensiune cauciuc: roți fata		nr	2
3.5 Ax de echilibru spate			No
3.6 Ecartament, față	b10	mm	155
3.7 Ecartament, spate	b11	mm	375

## Dimensiuni

4.4 Înălțime stivuitor	h3	mm	115
4.9 Height of tiller in drive position min	h14	mm	690
4.9 Înălțime manetă în poziția de deplasare, max	h14	mm	1160
4.15 Înălțime, coborât	h13	mm	90
4.19 Lungime globală	l1	mm	1596
4.20 Distanța până la suprafața frontală a furcilor	l2	mm	411
4.21 Lățime globală	b1	mm	555
4.22 Dimensiuni furcă - grosime	s	mm	60
4.22 Dimensiuni furcă - Lățime	e	mm	180
4.22 Dimensiuni furcă - Lungime	l	mm	1185
4.25 Distanța între furci	b5	mm	555
4.32 Gardă la sol și mijloc ampatament	m2	mm	30
4.34 Lățime culoar	Ast	mm	1851
4.35 Rază de virare	Wa	mm	1426

## Performante

5.2 Viteză de ridicare, încărcat	strokes		13
5.2 Viteză de ridicare, descărcat	strokes		13

**Cântar**

Tip	DFW 06 XPCA	
Cifre	Q.ty	6
Dimensiune cifră	mm	25
Kilograme		Yes
Livre		Yes
Greutate proprie		Yes
Oprire automata		Yes
Totalizare		Yes
Numărare		Yes
Timp de funcționare	h	50
Precizie	%	0.05
Celule de sarcină de tip forfecare	Q.ty	4
6.4 Capacitate acumulator	Ah	4

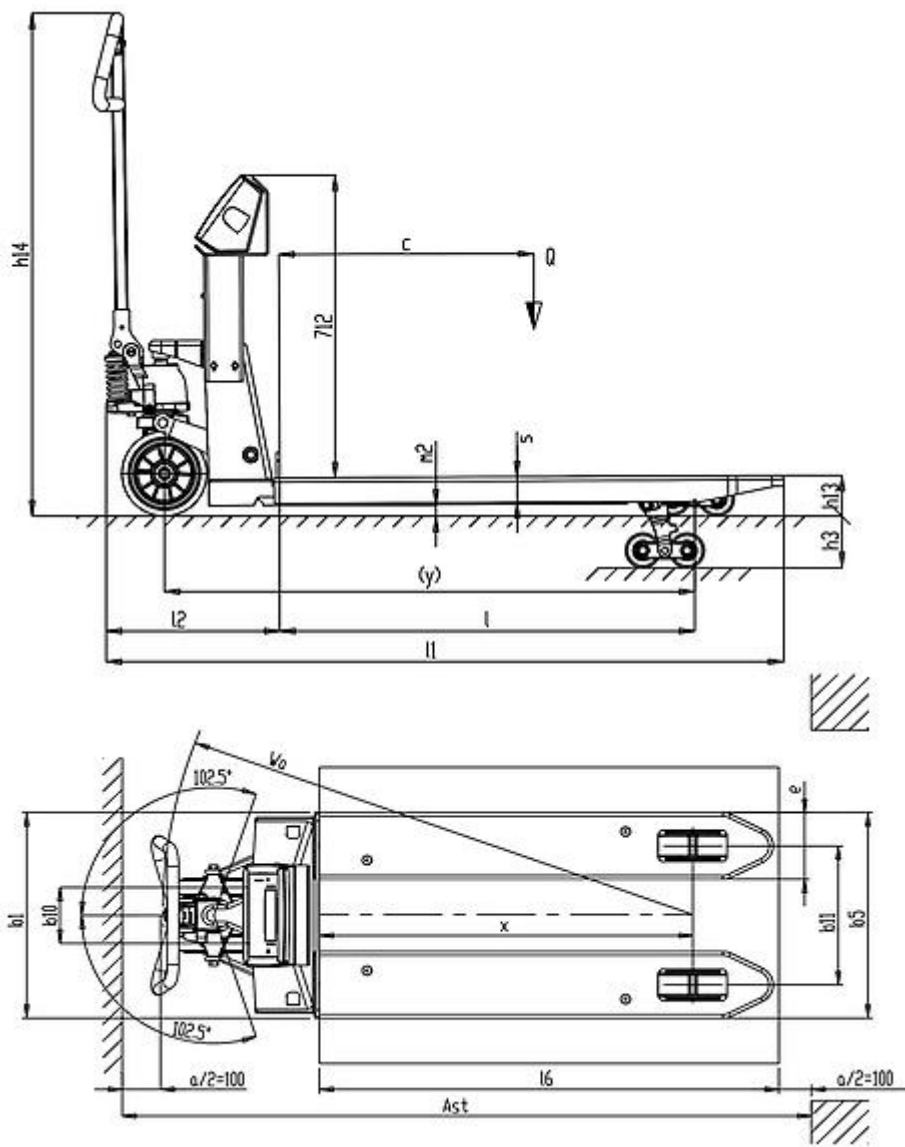

The information is aligned with the Data file at the time of download. Printed on 24/02/2020 (ID 590)

©2019 | PR INDUSTRIAL s.r.l. | All rights reserved | Image shown may not reflect actual package. Specifications subject to change without notice

